

ORDERING GUIDE

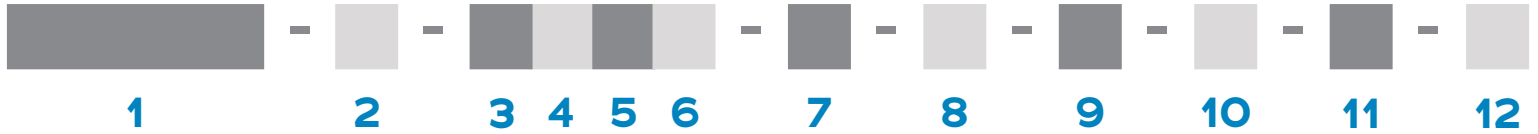

1 Series	MNPL Metal Nano Pin Latch MNSLP Metal Nano Socket Latch Panel	MNSL Metal Nano Socket Latch
2 Number Of Contacts	09 15 21 25 31 37 51 65	
3 Termination Type	AA Horizontal Surface Mount H4 Horizontal Thru-Hole	DD Thru-Hole Straight WD Discrete Wires FF Flex Tail
4 Wire Gage*	0 30 AWG (STD)	2 32 AWG
5 Wire Type*	Q NEMA HP3 (formerly M16878/4 and /6)	XX.X M22759/33 (30 AWG only)
6 Wire Length*	18.0 18.00" (STD)	XX.X Custom Length
7 Color Scheme*	C 10 Repeating Colors Per MIL STD 681	Y All Other Wire Colors
8 Shell Material & Finish	N Aluminum Shell, Electroless Nickel Plated B Aluminium Shell, Black Anodized T Titanium Shell, Unplated	CD Aluminium shell, Cadmium Plated S Stainless steel Shell, Passivated
9 Common Options	SR Strain Relief ** YY Non Standard Hardware (threaded holes, thumb screws, #2-56 screw) HT High Temp. Epoxy BS1 Standard Straight Backshell BS3 90/RA Oval BSY Custom Backshell	RH RoHS Compliant BS2 45 Oval BS4 2 Piece BS CS Customer Supplied Material
10 Shield / Jacket*	D Slip-on Braid E Machine Braid F Flexo Braid J Nomex Braid ST Shrink Tube	
11 Mod Codes	M10 Keyed M50 Space Grade Nano-D, SPT1	M30 Ground Spring M53 Space Grade Nano-D, SPT2
12 Special Instructions	YYY Describe anything that is not covered in standard options	

* WD only ** MNPL & MNSL only

DUAL ROW LATCHING BI-LOBE®

Omnetics' **Bi-Lobe®** connectors are available in a quick-latch version. This option requires no tools and makes it very easy for operators to achieve a secure connection in the field. These durable, lightweight connectors feature Omnetics' gold-plated Flex Pin contact system and ensure connectivity in the most demanding applications. They are spaced on .025" (.64 mm) centerlines and can carry 1 amp per contact. These connectors are available in standard sizes ranging from 9 to 65 positions, and can be configured with discrete wires, over-molded cable, panel mount housings, and PCB-mounted versions.



Electro-Mechanical Specifications

TYPE	PERFORMANCE
Durability	> 2000 Mating Cycles min
Temperature	-55°C to +125 °C (200 °C w/HTE)
Current rating	1 Amp per contact
Voltage Rating (DWV)	250 VAC RMS Sea Level
Insulation Resistance	5,000 Megohms @ 100 VDC
Shock	100 g's discontinuity < 10 nanoseconds
Vibration	20 g's discontinuity < 10 nanoseconds
Thermal Vacuum Outgassing	1.0% max TML, 0.1% VCM
Contact Resistance	71 milliohms (71 mV) max @ 1 Amp
Mating/Unmating Force	2.5 oz. (.71g) typical per contact

Material Specifications

TYPE	PERFORMANCE
Contact	Copper Alloy Per MIL-DTL-32139
Contact Finish	Gold per ASTM B488, Type II, Class 1.27, Code C Over Nickel Underplate
Insulator	Thermoplastic per MIL-M-24519
Encapsulant	Epoxy

Shell Options

TYPE	PERFORMANCE
Aluminum 6061	Electroless Nickel per SAE-AMS-2404
Stainless Steel, 300 Series	Passivated per SAE-AMS-2700

DUAL ROW LATCHING BI-LOBE® (TYPE AA)

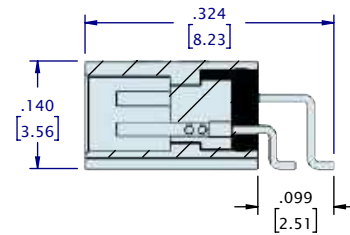
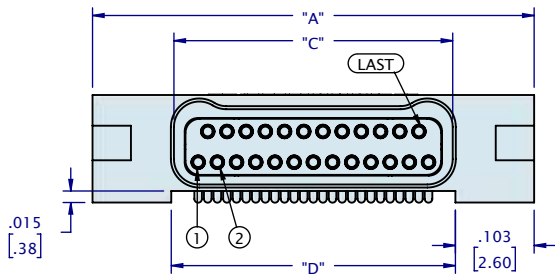
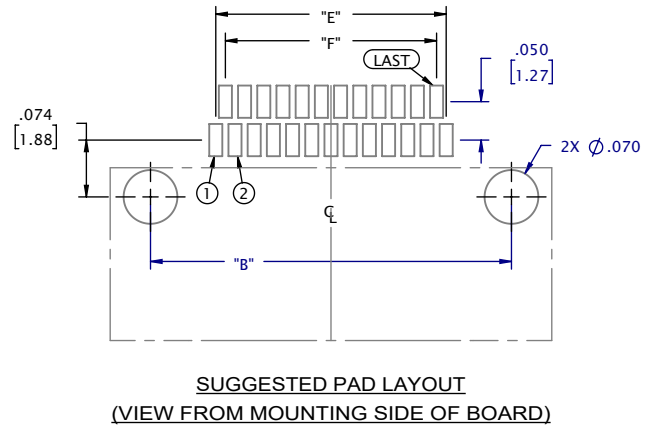
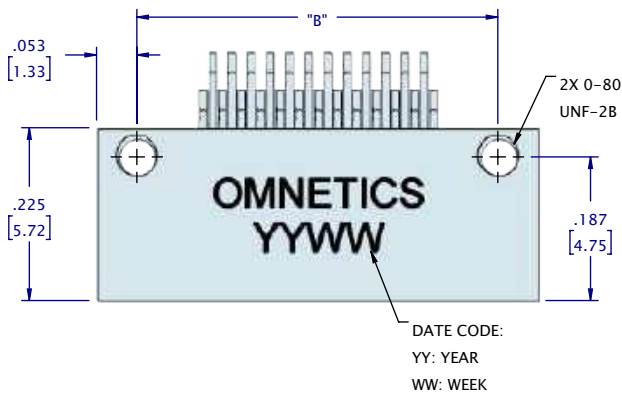

CONTACTS	"A"	"B"	"C"	"D"	"E"	"F"
09	.375 [9.53]	.270 [6.86]	.163 [4.14]	.170 [4.32]	.100 [2.54]	.075 [1.91]
15	.450 [11.43]	.345 [8.76]	.238 [6.05]	.245 [6.22]	.175 [4.45]	.150 [3.81]
21	.525 [13.34]	.420 [10.67]	.313 [7.95]	.320 [8.13]	.250 [6.35]	.225 [5.72]
25	.575 [14.61]	.470 [11.94]	.363 [9.22]	.370 [9.40]	.300 [7.62]	.275 [6.99]
31	.650 [16.51]	.545 [13.84]	.438 [11.13]	.445 [11.30]	.375 [9.53]	.350 [8.89]
37	.725 [18.42]	.620 [15.75]	.513 [13.03]	.520 [13.21]	.450 [11.43]	.425 [10.80]
51	.900 [22.86]	.795 [20.19]	.688 [17.48]	.695 [17.65]	.625 [15.88]	.600 [15.24]
65	1.075 [27.31]	.970 [24.64]	.863 [21.92]	.870 [22.10]	.800 [20.32]	.775 [19.69]

DIMENSIONS IN [] ARE IN MILLIMETERS AND ARE FOR REFERENCE ONLY

DUAL ROW LATCHING BI-LOBE® (TYPE AA)

PANEL MOUNT

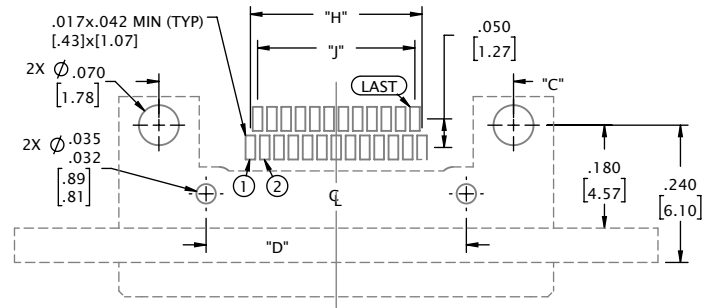
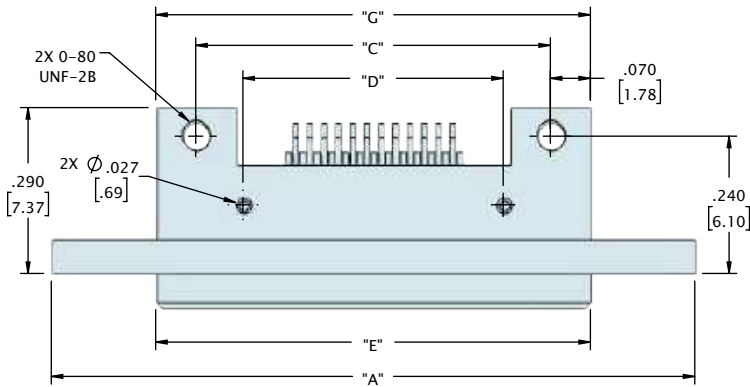

SUGGESTED PAD LAYOUT
(VIEW FROM MOUNTING SIDE OF BOARD)

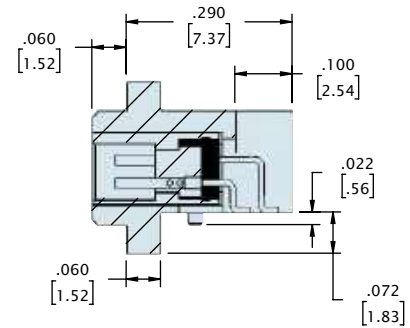
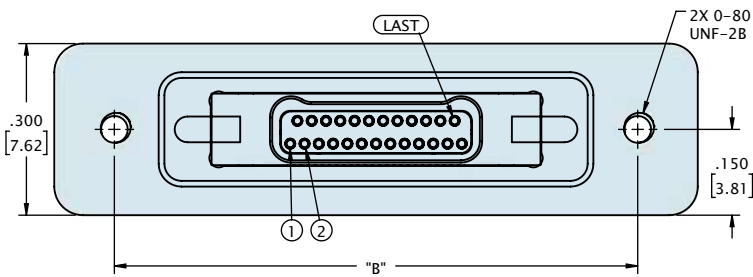

CONTACTS	"A"	"B"	"C"	"D"	"E"	"F"	"G"	"H"	"J"
09	.925 [23.50]	.715 [18.16]	.420 [10.67]	.255 [6.48]	.560 [14.22]	.279 [7.09]	.560 [14.22]	.075 [1.91]	.100 [2.54]
15	1.000 [25.40]	.790 [20.07]	.495 [12.57]	.330 [8.38]	.635 [16.13]	.354 [8.99]	.635 [16.13]	.150 [3.81]	.175 [4.45]
21	1.075 [27.31]	.865 [21.97]	.570 [14.48]	.405 [10.29]	.710 [18.03]	.429 [10.90]	.710 [18.03]	.225 [5.72]	.250 [6.35]
25	1.125 [28.58]	.915 [23.24]	.620 [15.75]	.455 [11.56]	.760 [19.30]	.479 [12.17]	.760 [19.30]	.275 [6.99]	.300 [7.62]
31	1.200 [30.48]	.990 [25.15]	.695 [17.65]	.530 [13.46]	.835 [21.21]	.554 [14.07]	.835 [21.21]	.350 [8.89]	.375 [9.53]
37	1.275 [32.39]	1.065 [27.05]	.770 [19.56]	.605 [15.37]	.910 [23.11]	.629 [15.98]	.910 [23.11]	.425 [10.80]	.450 [11.43]
51	1.450 [36.83]	1.240 [31.50]	.945 [24.00]	.780 [19.81]	1.085 [27.56]	.804 [20.42]	1.085 [27.56]	.600 [15.24]	.625 [15.88]
65	1.625 [41.28]	1.415 [35.94]	1.120 [28.45]	.955 [24.26]	1.260 [32.00]	.979 [24.87]	1.260 [32.00]	.775 [19.69]	.800 [20.32]

DIMENSIONS IN [] ARE IN MILLIMETERS AND ARE FOR REFERENCE ONLY

DUAL ROW LATCHING BI-LOBE® (TYPE DD)

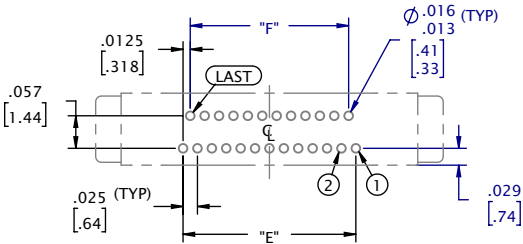
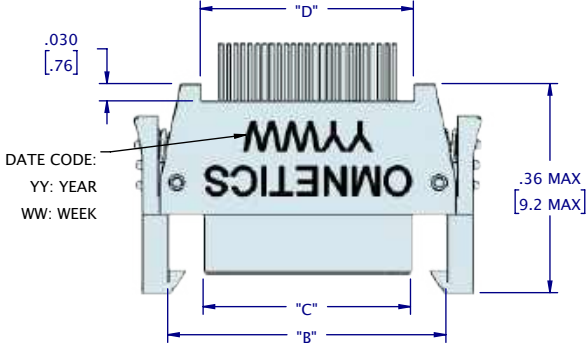

SUGGESTED PAD LAYOUT
(VIEW FROM MOUNTING SIDE OF BOARD)

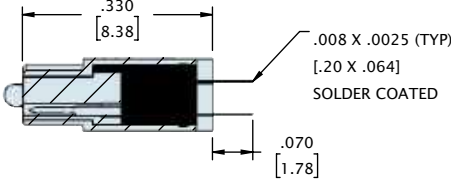
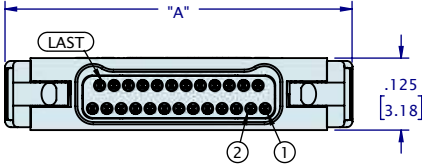

CONTACTS	"A"	"B"	"C"	"D"	"E"	"F"
09	.403 [10.25]	.283 [7.19]	.160 [4.06]	.170 [4.32]	.100 [2.54]	.075 [1.91]
15	.478 [12.15]	.358 [9.09]	.235 [5.97]	.245 [6.22]	.175 [4.45]	.150 [3.81]
21	.553 [14.06]	.433 [11.00]	.310 [7.87]	.320 [8.13]	.250 [6.35]	.225 [5.72]
25	.603 [15.33]	.483 [12.27]	.360 [9.14]	.370 [9.40]	.300 [7.62]	.275 [6.99]
31	.678 [17.23]	.558 [14.17]	.435 [11.05]	.445 [11.30]	.375 [9.53]	.350 [8.89]
37	.753 [19.14]	.633 [16.08]	.510 [12.95]	.520 [13.21]	.450 [11.43]	.425 [10.80]
51	.928 [23.58]	.808 [20.52]	.685 [17.40]	.695 [17.65]	.625 [15.88]	.600 [15.24]
65	1.103 [28.03]	.983 [24.97]	.860 [21.84]	.870 [22.10]	.800 [20.32]	.775 [19.69]

DIMENSIONS IN [] ARE IN MILLIMETERS AND ARE FOR REFERENCE ONLY

DUAL ROW LATCHING BI-LOBE® (TYPE DD)

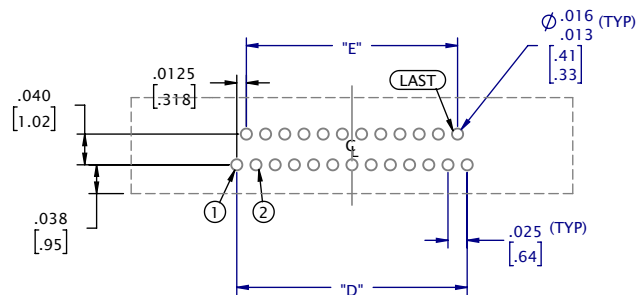
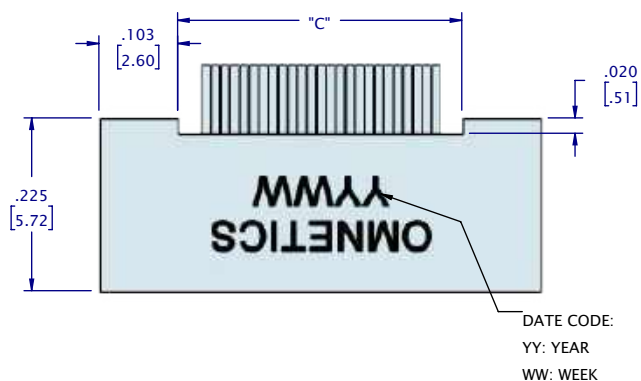

SUGGESTED PAD LAYOUT
(VIEW FROM MOUNTING SIDE OF BOARD)

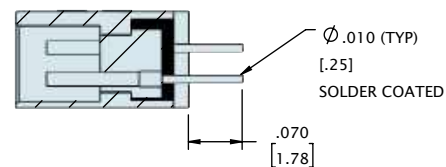
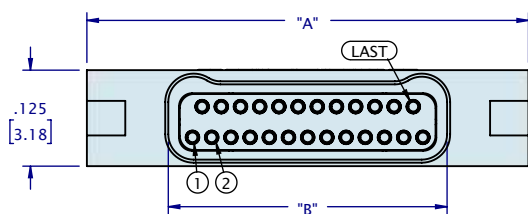

CONTACTS	"A"	"B"	"C"	"D"	"E"
09	.375 [9.53]	.163 [4.14]	.170 [4.32]	.100 [2.54]	.075 [1.91]
15	.450 [11.43]	.238 [6.05]	.245 [6.22]	.175 [4.45]	.150 [3.81]
21	.525 [13.34]	.313 [7.95]	.320 [8.13]	.250 [6.35]	.225 [5.72]
25	.575 [14.61]	.363 [9.22]	.370 [9.40]	.300 [7.62]	.275 [6.99]
31	.650 [16.51]	.438 [11.13]	.445 [11.30]	.375 [9.53]	.350 [8.89]
37	.725 [18.42]	.513 [13.03]	.520 [13.21]	.450 [11.43]	.425 [10.80]
51	.900 [22.86]	.688 [17.48]	.695 [17.65]	.625 [15.88]	.600 [15.24]
65	1.075 [27.31]	.863 [21.92]	.870 [22.10]	.800 [20.32]	.775 [19.69]

DIMENSIONS IN [] ARE IN MILLIMETERS AND ARE FOR REFERENCE ONLY

DUAL ROW LATCHING BI-LOBE® (TYPE DD)

PANEL MOUNT

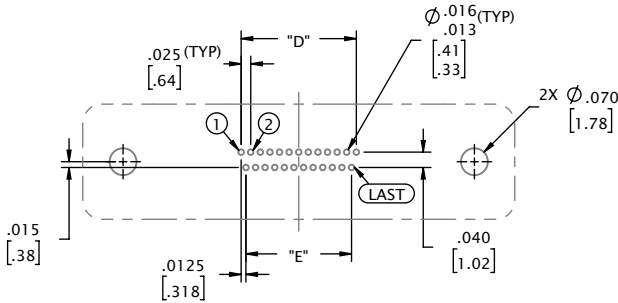
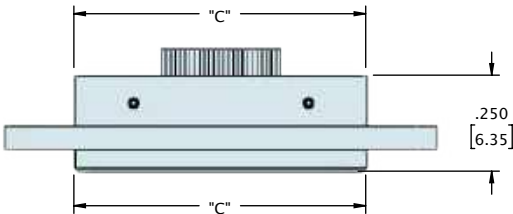

SUGGESTED PAD LAYOUT
(VIEW FROM MOUNTING SIDE OF BOARD)

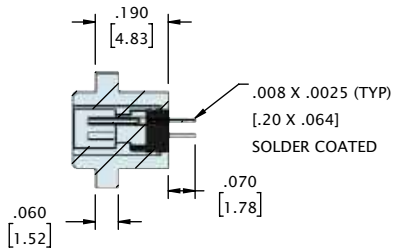
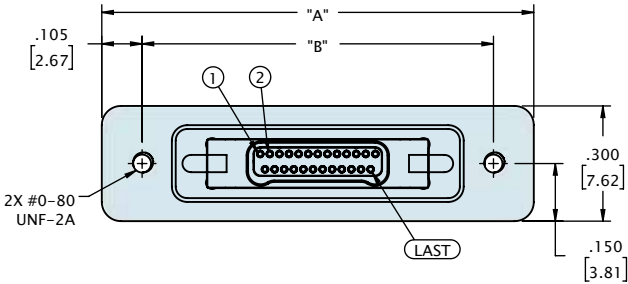

CONTACTS	"A"	"B"	"C"	"D"	"E"
09	.925 [23.50]	.715 [18.16]	.560 [14.22]	.100 [2.54]	.075 [1.91]
15	1.000 [25.40]	.790 [20.07]	.635 [16.13]	.175 [4.45]	.150 [3.81]
21	1.075 [27.31]	.865 [21.97]	.710 [18.03]	.250 [6.35]	.225 [5.72]
25	1.125 [28.58]	.915 [23.24]	.760 [19.30]	.300 [7.62]	.275 [6.99]
31	1.200 [30.48]	.990 [25.15]	.835 [21.21]	.375 [9.53]	.350 [8.89]
37	1.275 [32.39]	1.065 [27.05]	.910 [23.11]	.450 [11.43]	.425 [10.80]
51	1.450 [36.83]	1.240 [31.50]	1.085 [27.56]	.625 [15.88]	.600 [15.24]
65	1.625 [41.28]	1.415 [35.94]	1.260 [32.00]	.800 [20.32]	.775 [19.69]

DUAL ROW LATCHING BI-LOBE® (TYPE FF)

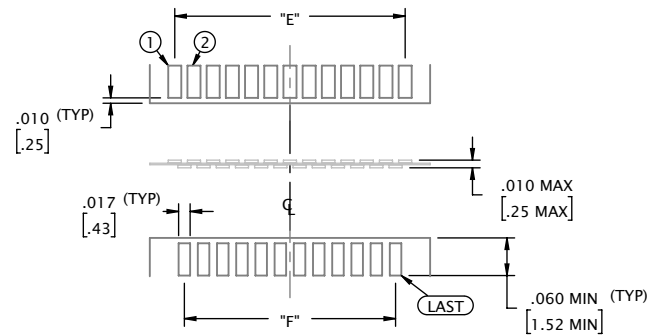
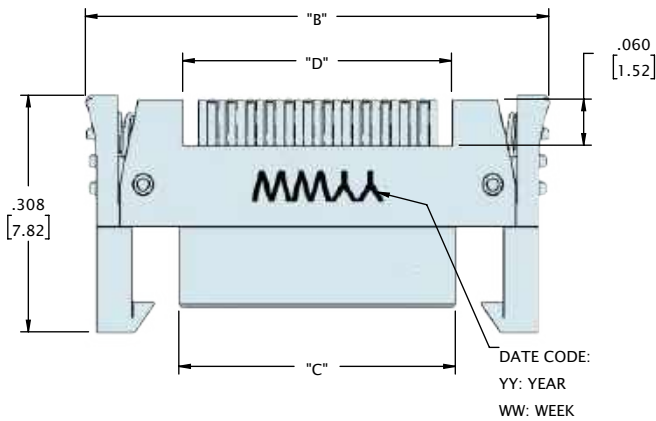

SUGGESTED PAD LAYOUT
(VIEW FROM MOUNTING SIDE OF BOARD)

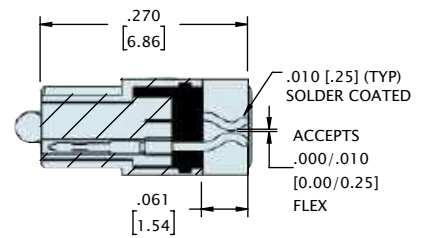
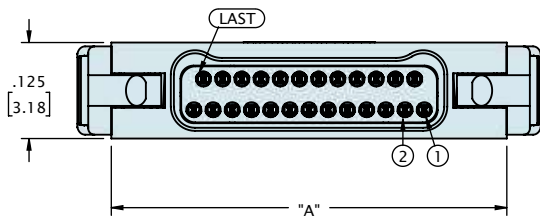

CONTACTS	"A"	"B"	"C"	"D"	"E"	"F"
09	.404 [10.25]	.283 [7.19]	.160 [4.06]	.150 [3.81]	.100 [2.54]	.075 [1.90]
15	.479 [12.15]	.358 [9.09]	.235 [5.97]	.225 [5.72]	.175 [4.45]	.150 [3.81]
21	.554 [14.06]	.433 [11.00]	.310 [7.87]	.300 [7.62]	.250 [6.35]	.225 [5.71]
25	.604 [15.33]	.483 [12.27]	.360 [9.14]	.350 [8.89]	.300 [7.62]	.275 [6.98]
31	.679 [17.23]	.558 [14.17]	.435 [11.05]	.425 [10.80]	.375 [9.53]	.350 [8.89]
37	.754 [19.14]	.633 [16.08]	.510 [12.95]	.500 [12.70]	.450 [11.43]	.425 [10.79]
51	.929 [23.58]	.808 [20.52]	.685 [17.40]	.675 [17.15]	.625 [15.88]	.600 [15.24]
65	1.104 [28.03]	.983 [24.97]	.860 [21.84]	.850 [21.59]	.800 [20.32]	.775 [19.68]

DIMENSIONS IN [] ARE IN MILLIMETERS AND ARE FOR REFERENCE ONLY

DUAL ROW LATCHING BI-LOBE® (TYPE FF)

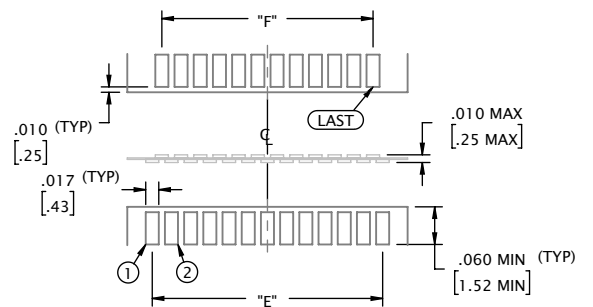
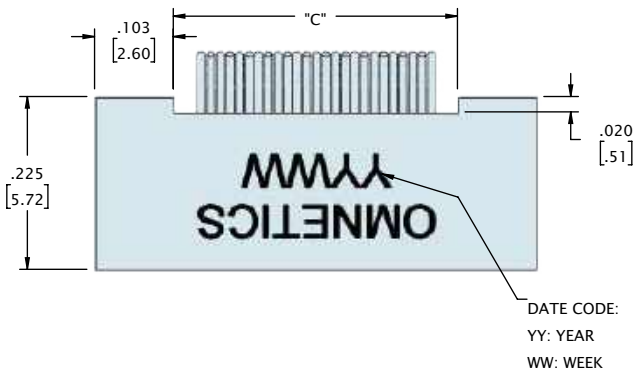

SUGGESTED PAD LAYOUT
(VIEW FROM MOUNTING SIDE OF BOARD)

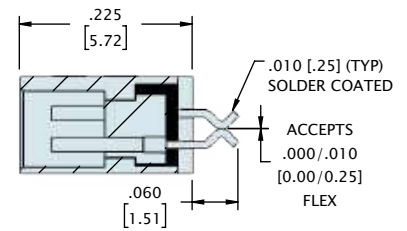
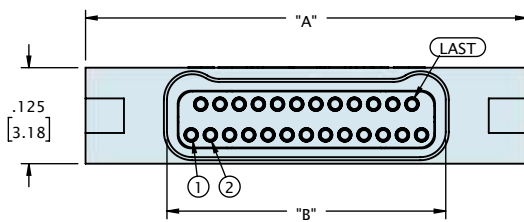

CONTACTS	"A"	"B"	"C"	"D"	"E"
09	.375 [9.53]	.163 [4.14]	.170 [4.32]	.100 [2.54]	.075 [1.91]
15	.450 [11.43]	.238 [6.05]	.245 [6.22]	.175 [4.44]	.150 [3.81]
21	.525 [13.34]	.313 [7.95]	.320 [8.13]	.250 [6.35]	.225 [5.72]
25	.575 [14.61]	.363 [9.22]	.370 [9.40]	.300 [7.62]	.275 [6.99]
31	.650 [16.51]	.438 [11.13]	.445 [11.30]	.375 [9.52]	.350 [8.89]
37	.725 [18.42]	.513 [13.03]	.520 [13.21]	.450 [11.43]	.425 [10.80]
51	.900 [22.86]	.688 [17.48]	.695 [17.65]	.625 [15.88]	.600 [15.24]
65	1.075 [27.31]	.863 [21.92]	.870 [22.10]	.800 [20.32]	.775 [19.69]

DIMENSIONS IN [] ARE IN MILLIMETERS AND ARE FOR REFERENCE ONLY

DUAL ROW LATCHING BI-LOBE® (TYPE H4)

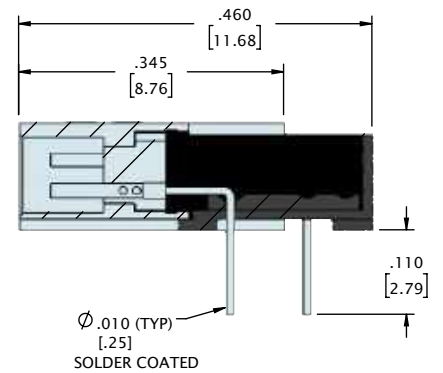
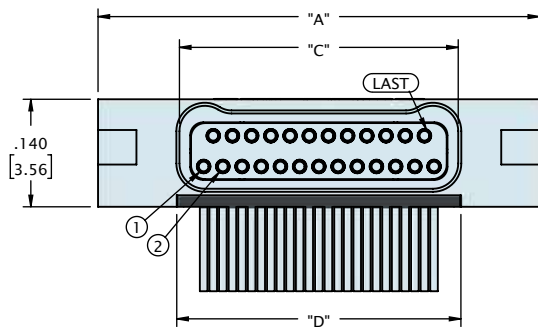
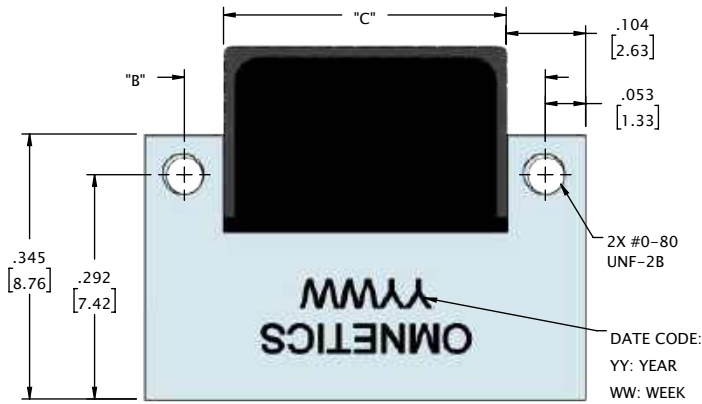
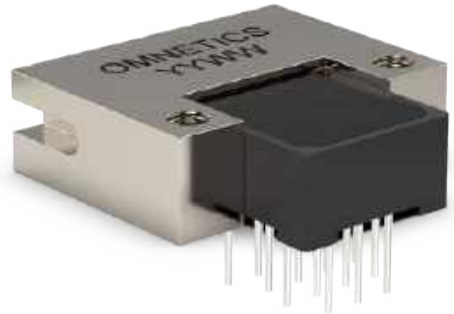

CONTACTS	"A"	"B"	"C"	"D"
09	.375 [9.53]	.270 [6.86]	.163 [4.14]	.170 [4.32]
15	.450 [11.43]	.345 [8.76]	.238 [6.05]	.245 [6.22]
21	.525 [13.34]	.420 [10.67]	.313 [7.95]	.320 [8.13]
25	.575 [14.61]	.470 [11.94]	.363 [9.22]	.370 [9.40]
31	.650 [16.51]	.545 [13.84]	.438 [11.13]	.445 [11.30]
37	.725 [18.42]	.620 [15.75]	.513 [13.03]	.520 [13.21]
51	.900 [22.86]	.795 [20.19]	.688 [17.48]	.695 [17.65]
65	1.075 [27.31]	.970 [24.64]	.863 [21.92]	.870 [22.10]

DIMENSIONS IN [] ARE IN MILLIMETERS AND ARE FOR REFERENCE ONLY

DUAL ROW LATCHING BI-LOBE® (TYPE H4)

9 CONTACT SOCKET

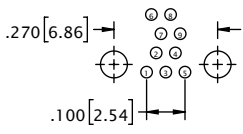

21 CONTACT SOCKET

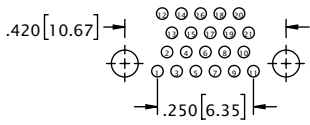

31 CONTACT SOCKET

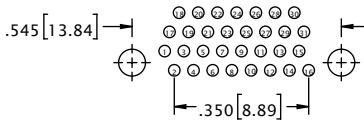

51 CONTACT SOCKET

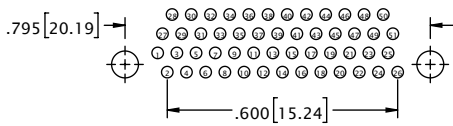

15 CONTACT SOCKET

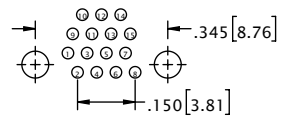

25 CONTACT SOCKET

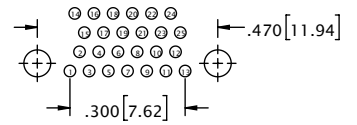

37 CONTACT SOCKET

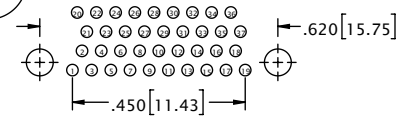

65 CONTACT SOCKET

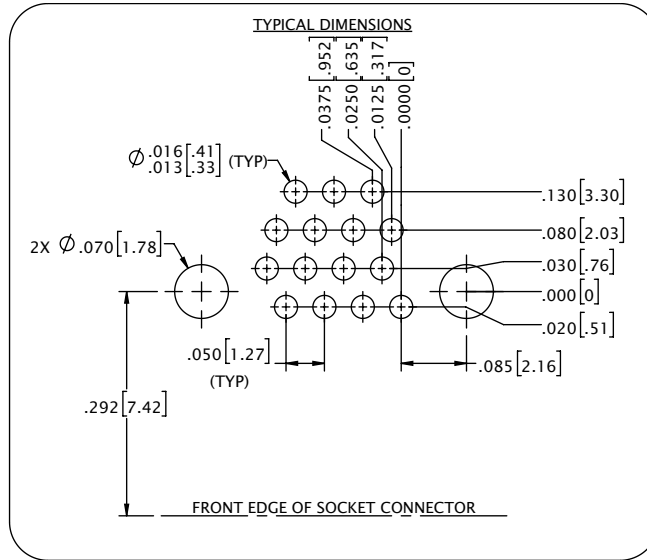
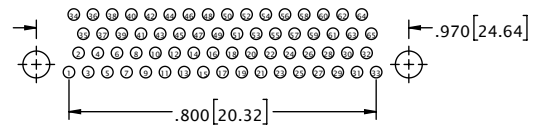

DUAL ROW LATCHING BI-LOBE® (TYPE VV)

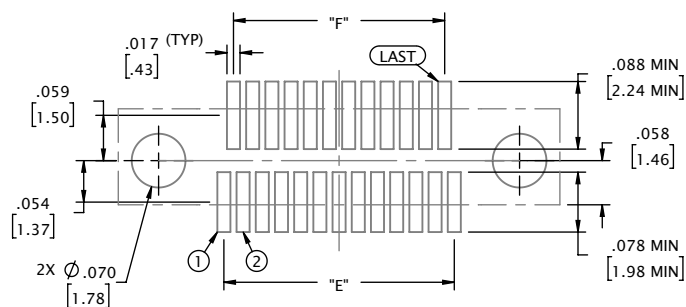
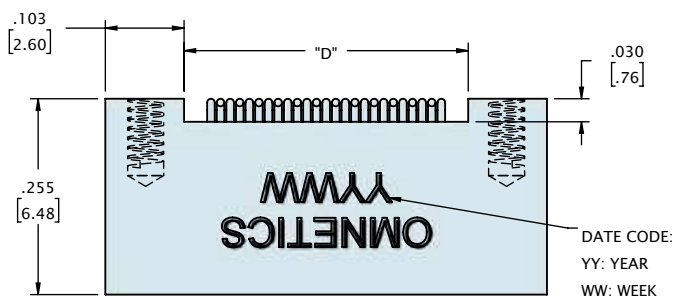

SUGGESTED PAD LAYOUT
(VIEW FROM MOUNTING SIDE OF BOARD)

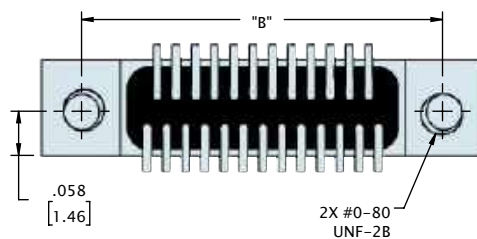
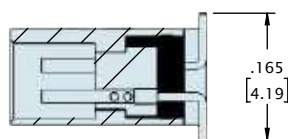
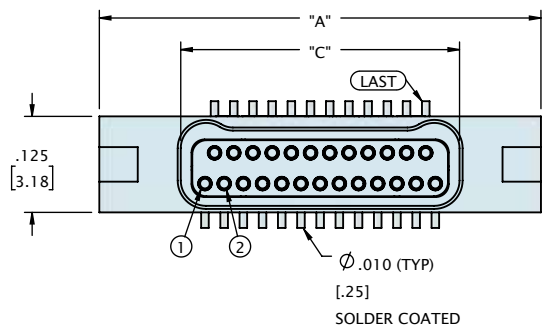

CONTACTS	"A"	"B"	"C"	"D"	"E"	"F"
09	.375 [9.53]	.270 [6.86]	.163 [4.14]	.170 [4.32]	.100 [2.54]	.075 [1.91]
15	.450 [11.43]	.345 [8.76]	.238 [6.05]	.245 [6.22]	.175 [4.45]	.150 [3.81]
21	.525 [13.34]	.420 [10.67]	.313 [7.95]	.320 [8.13]	.250 [6.35]	.225 [5.72]
25	.575 [14.61]	.470 [11.94]	.363 [9.22]	.370 [9.40]	.300 [7.62]	.275 [6.99]
31	.650 [16.51]	.545 [13.84]	.438 [11.13]	.445 [11.30]	.375 [9.53]	.350 [8.89]
37	.725 [18.42]	.620 [15.75]	.513 [13.03]	.520 [13.21]	.450 [11.43]	.425 [10.80]
51	.900 [22.86]	.795 [20.19]	.688 [17.48]	.695 [17.65]	.625 [15.88]	.600 [15.24]
65	1.075 [27.31]	.970 [24.64]	.863 [21.92]	.870 [22.10]	.800 [20.32]	.775 [19.69]

DIMENSIONS IN [] ARE IN MILLIMETERS AND ARE FOR REFERENCE ONLY

DUAL ROW LATCHING BI-LOBE® (TYPE WD)

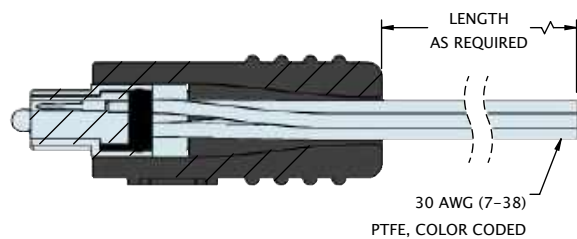
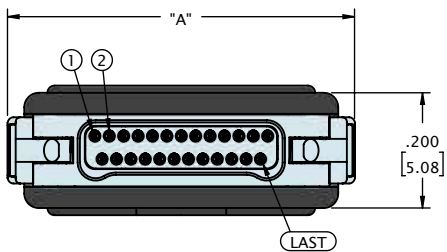
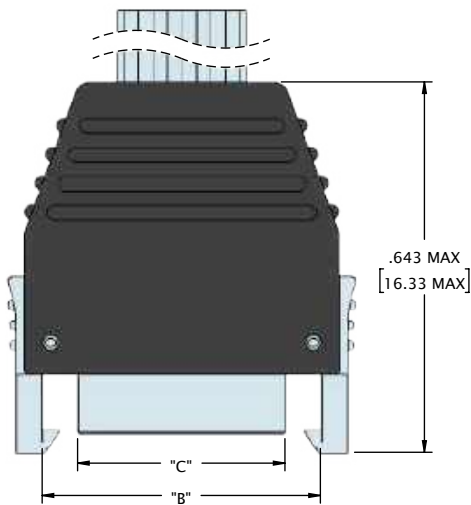

CONTACTS	"A"	"B"	"C"
09	.403 [10.25]	.283 [7.19]	.160 [4.06]
15	.478 [12.15]	.358 [9.09]	.235 [5.97]
21	.553 [14.06]	.433 [11.00]	.310 [7.87]
25	.603 [15.33]	.483 [12.27]	.360 [9.14]
31	.678 [17.23]	.558 [14.17]	.435 [11.05]
37	.753 [19.14]	.633 [16.08]	.510 [12.95]
51	.928 [23.58]	.808 [20.52]	.685 [17.40]
65	1.103 [28.03]	.983 [24.97]	.860 [21.84]

DIMENSIONS IN [] ARE IN MILLIMETERS AND ARE FOR REFERENCE ONLY

DUAL ROW LATCHING BI-LOBE® (TYPE WD)

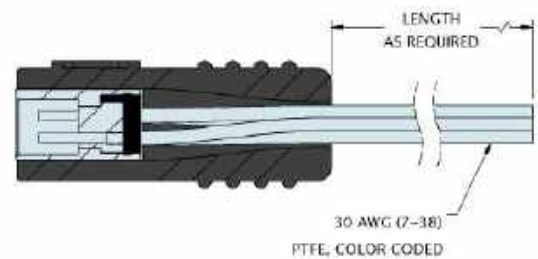
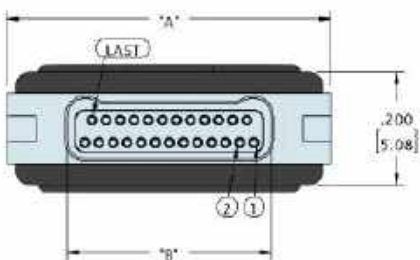
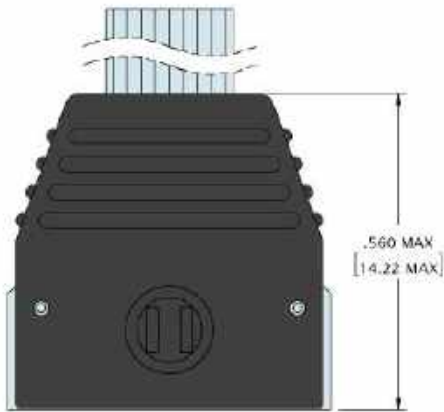

CONTACTS	"A"	"B"
09	.375 [9.53]	.163 [4.14]
15	.450 [11.43]	.238 [6.05]
21	.525 [13.34]	.313 [7.95]
25	.575 [14.61]	.363 [9.22]
31	.650 [16.51]	.438 [11.13]
37	.725 [18.42]	.513 [13.03]
51	.900 [22.86]	.688 [17.48]
65	1.075 [27.31]	.863 [21.92]

DIMENSIONS IN [] ARE IN MILLIMETERS AND ARE FOR REFERENCE ONLY

DUAL ROW LATCHING BI-LOBE® (TYPE WD)

PANEL MOUNT

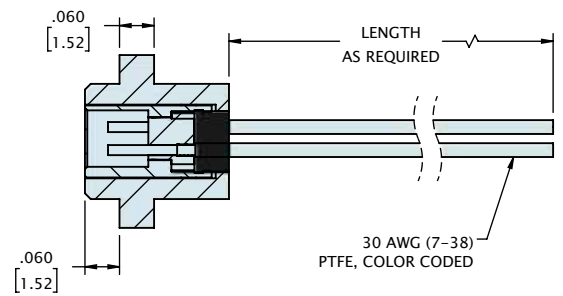
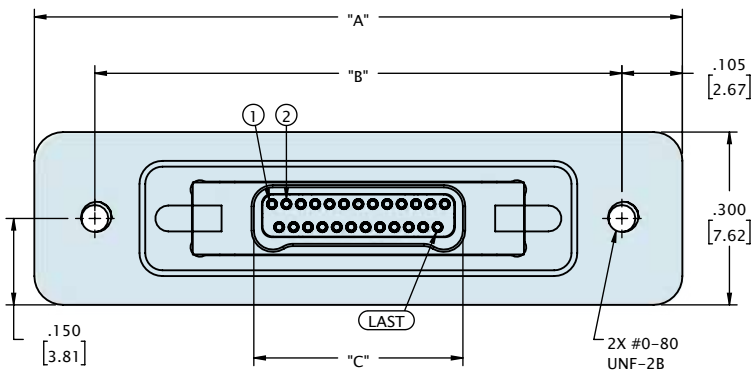
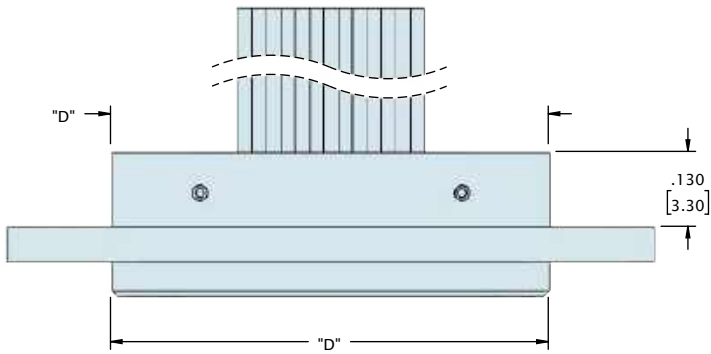
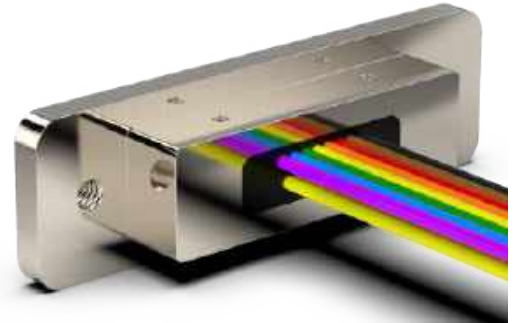

CONTACTS	"A"	"B"	"C"	"D"
09	.925 [23.50]	.715 [18.16]	.163 [4.14]	.560 [14.22]
15	1.000 [25.40]	.790 [20.07]	.238 [6.05]	.635 [16.13]
21	1.075 [27.31]	.865 [21.97]	.313 [7.95]	.710 [18.03]
25	1.125 [28.58]	.915 [23.24]	.363 [9.22]	.760 [19.30]
31	1.200 [30.48]	.990 [25.15]	.438 [11.13]	.835 [21.21]
37	1.275 [32.39]	1.065 [27.05]	.513 [13.03]	.910 [23.11]
51	1.450 [36.83]	1.240 [31.50]	.688 [17.48]	1.085 [27.56]
65	1.625 [41.28]	1.415 [35.94]	.863 [21.92]	1.260 [32.00]

DIMENSIONS IN [] ARE IN MILLIMETERS AND ARE FOR REFERENCE ONLY